



F900 SERIES

User, installation and servicing instructions

BOILING PAN

E9781

Read these instructions before use

DATE PURCHASED:

MODEL NUMBER:

SERIAL NUMBER:

DEALER:

SERVICE PROVIDER:

T100951

REV. 5

Dear Customer,
Thank you for choosing Falcon Foodservice Equipment.

This manual can be downloaded from www.falconfoodservice.com or scan here.



IMPORTANT: Please keep this manual for future reference.

Falcon Foodservice Equipment

HEAD OFFICE

Wallace View, Hillfoots Road, Stirling. FK9 5PY. Scotland.

e-mail: info@FalconF900.com



WEEE Directive Registration No. WEE/DC0059TT/PRO

At end of appliance life, dispose of appliance and any replacement parts in a safe manner, via a licensed waste handler. Appliances are designed to be dismantled easily and recycling of all material is encouraged whenever practicable.



- **These instructions are only valid if the country code appears on the appliance. If the code does not appear on the appliance, refer to the technical instructions for adapting the appliance to the conditions for use in that country.**
- **Installation must meet national or local regulations. Attention must be paid to: gas safety (installation & use) regulations, health and safety at work act, local and national building regulations, fire precautions act.**
- **To prevent shocks, all appliances must be earthed.**
- **This appliance has been CE-marked on the basis of compliance with the Low Voltage and EMC Directives for the voltages stated on the data plate.**
- **This equipment is for professional use only and must be used by qualified persons.**
- **The installer must instruct the responsible person(s) of the correct operation and maintenance of the appliance.**
- **Only competent persons are allowed to service or convert the appliance to another gas type.**
- **Gas appliances must have a stop cock fitted in the supply pipe work. The user must be familiar with the location and operation of this device in order to turn off the supply of gas in the event of an emergency.**
- **Unless otherwise stated, parts which have been protected by the manufacturer must not be adjusted by the installer.**
- **Take care when moving an appliance fitted with castors.**
- **The appliance must be serviced regularly by a qualified person. Service intervals should be agreed with the service provider.**
- **Check that no damage has occurred to the appliance, power cable, or plug during transit. If damage has occurred, do not use this appliance.**



- **Installation, periodic testing, repair and fixed wiring connections should only be undertaken by a competent electrician.**
- **Ensure power cable is routed free from the appliance to avoid damage.**
- **We recommend supplementary electrical protection with the use of a residual current device (RCD).**
- **The appliance has been designed and approved to use Falcon kick plates, non Falcon kick plates could potentially adversely affect the performance of the appliance by restricting the air to the appliance.**

IMPORTANT INSTALLATION INFORMATION

Electrical Safety and Advice Regarding Supplementary Electrical Protection

Commercial kitchens and foodservice areas are environments where electrical appliances may be located close to liquids, or operate in and around damp conditions, or where restricted movement for installation and service is evident.

The installation and periodic inspection of the appliance should only be undertaken by a qualified, skilled and competent electrician; and connected to the correct power supply suitable for load as stipulated by the appliance data label.

The electrical installation and connections should meet the necessary requirements to local electrical wiring regulations and electrical safety guidelines.

WE RECOMMEND:- Supplementary electrical protection with use of a residual current device (RCD).

Fixed wiring appliances incorporate a locally-situated switch disconnecter to connect to, which is easily accessible for switching off and safe isolation purposes.

The switch disconnecter must meet the specification requirements of IEC 60947.

Part 1: General reminders and notes

1.1	General reminders	6
1.2	Technical data	7
1.3	Construction	7
1.3.1	Details only for pressure kettles	7
1.4	Laws, technical prescriptions and directives	7
1.5	Special requirements for the installation site	7

Part 2: Positioning, installation and maintenance

2.1	Positioning	8
2.2	Installation	8
2.2.1	Electrical connections and equipotential bonding	8
2.2.2	Connection to waterworks	8
2.3	Commissioning and testing	9
2.4	Maintenance of the appliance	9
2.4.1	Possible failures and their elimination	9

Part 3: Use and cleaning

3.1	Warnings and hints for user	10
3.2	Instructions for use	10
3.2.1	Filling the jacket	10
3.2.2	Details regarding the operation of the pressure kettles	10
3.2.3	Switch on, start of cooking and switch off	11
3.3	Cleaning and care of the appliance	11
3.3.1	Daily cleaning	11
3.4	Special procedures in case of long unit inactivity	11
3.5	Special procedures in case of failures	12
3.6	How to proceed, if ...	12

Part 4: Figures and details

4.1	Wiring diagram	13 - 14
4.2	View of appliance	15
4.3	Controls	16

Section 1: General reminders and notes

1.1 GENERAL REMINDERS

Read the warnings contained in this manual carefully as they provide important information concerning safety during the installation, use and maintenance of the appliance.

Keep these instructions safe for reference!

Only personnel trained specifically to use the equipment should operate it.

Keep appliance under control during use.

The appliance should be used only for the purpose for which it has been specifically designed; other uses are improper and hence dangerous.

During operation surfaces can become hot and require special operation.

Unplug appliance in case of failures or improper operation.

Apply exclusively to a service centre for repairs or maintenance.

Any important information about the appliance required for technical service is contained in the technical data plate (*see figure "View of appliance"*).

If technical assistance is required, the problem must be described in as much detail as possible, so that a service technician will be able to assist with solving it.

Gloves should be worn during installation and maintenance operations.

Warning! : Follow the fire prevention regulations very carefully.

1.2 TECHNICAL DATA

1.2. Technical data			
Description	Unit of measurement	100LT	150LT
Width	mm	800	
Depth	mm	900	
Height	mm	900	
PAN diameter	mm	600	
PAN height	mm	415	540
Total volume	l	110	150
Usable volume	l	100	139
Voltage/Input		3 N AC 400V / 50 Hz	
Power	kW	16	18
Power cable	mm ²	5x6	
Water connection	mm	3/4"	
Water pressure	kPa	50 – 300	
Jacket pressure	bar	0,5	

1.3 CONSTRUCTION

Main structure is AISI 430 with 4 adjustable feet.

Panels are stainless steel AISI 304, thickness 10-12/10.

Stainless steel pan is AISI 316, thickness 20/10.

Chrome-plated brass drainage tap.

Lid is stainless steel, hinged and spring-balanced in all opening positions.

Stainless steel jacket and lining is AISI 304, thickness 15-20/10.

Heating system comprising shielded heating elements made from "Incoloy-800" alloy with boiler and steam circulation.

Jacket pressure is controlled by a safety valve set at 0.5 bar; appliance is equipped with an analogue pressure gauge.

Water connection is 3/4".

Safety thermostat will cut power in the event of a problem.

The appliance is equipped with a three-position selector with three heating functions:

Position "0" Heating not activated

Position "1" Reduced power (50%)

Position "2" Full power (100%)

Operating thermostat for temperature adjustment is located inside cooking pan.

1.3.1 DETAILS ONLY FOR PRESSURE KETTLES

Stainless steel lid is supplied with heat-resistant silicone gasket.

Hermetic closing of lid is ensured by 4 screw clamps.

The relief valve for the pressure that develops inside the cooking pan is set at 0.05 bar.

On request, the appliance can be supplied with a pressure gauge that will indicate the pressure inside the cooking pan.

1.4 LAWS, TECHNICAL PRESCRIPTIONS AND DIRECTIVES

When installing the appliance it is necessary to follow and comply with the following regulations:

Current regulations on the matter;

Hygienic-sanitary regulations concerning cooking environments;

Municipal and/or territorial building regulations and fire prevention prescriptions;

Current accident prevention guidelines;

Electricity board regulations concerning safety;

Regulations of the electrical power supply company or agency;

Other local regulations.

1.5 SPECIAL REQUIREMENTS FOR THE INSTALLATION SITE

The room in which the appliance is to operate must be well ventilated.

In addition, it is good policy to locate the appliance under an extractor hood so that cooking vapours can be removed rapidly and continuously.

Current regulations require the installation of a multiple pole switch between the appliance and the electrical power supply; the switch must have a contact gap of least 3 mm on each pole.

This appliance requires two water connections: one for hot and one for cold water. Each line must be fitted with an on-off valve.

Warning! : The electrical isolating switch and water shut off valves must both be located close to the appliance, within easy reach of the user.

Part 2: Positioning, installation and maintenance

2.1 POSTIONING

Remove all packaging and check that the appliance is in perfect condition.

In case of visible damage, do not connect the appliance and notify the sales point immediately.

Remove PVC protection from all panels.

Dispose of packaging according to regulations. Generally material is divided according to composition and should be delivered to the waste disposal service.

There are no special instructions regarding distances from other appliances or walls however, it is advisable to maintain a sufficient distance to allow any service function to be carried out. In the event that the appliance is installed in direct contact with flammable walls, it will be necessary to fit suitable heat insulation.

The appliance must be levelled. Small differences in level can be achieved by adjusting the legs as required. A significantly uneven surface or sloping may adversely affect operation of the appliance.

2.2 INSTALLATION

Warning! : Only qualified technicians must perform the installation, maintenance and testing of the appliance.

Warning! : Before connecting any parts of the appliance to supplies, make sure that the supplies are equivalent to requirements stated on the unit data plate, if appliance has been designed to operate on these supplies.

2.2.1 ELECTRICAL CONNECTIONS AND EQUIPOTENTIAL BONDING

Warning! : The appliance operates in accordance with power supply indicated on the data plate.

As mentioned, appliance must be connected to power supply by way of a multiple pole main isolating switch and protection device that must be proportioned to the power of the appliance (1mA per kW of rated power).

The earthing system must be efficient.

This appliance is type X equipment (*delivery without power cable and plug*), the cable and other hardware needed to connect to the electrical power supply must be provided by the installer.

The power cable shall be of type described in the paragraph "Technical data" and shall be resistant to oil.

Power terminal board can be reached by removing lower front panel (*undo fixings*). The cable fastener is located at lower right-hand side.

The cable must be fed in from below clamp. The individual wires are then fastened to corresponding terminals of terminal board. The earth wire must be longer than the other cables, so that in the event of this being jerked or the clamp broken, live wires will disconnect first. Lock cord fastener.

The appliance must incorporate an equipotential system.

Connect terminal on lower right-hand side marked with the international symbol to a connector with a nominal cross section <10 mm.

All appliances being installed will be connected using this earthing system.

2.2.2 CONNECTION TO WATERWORKS

Water inlet pressure must be between 50 and 300 kPa, otherwise install a pressure regulator on the line before the appliance.

Install a cut-off valve for each supply on the line before the appliance.

10mm water connections 10mm are located at the lower right hand side of appliance.

Connect to water supply according to regulations currently in force.

2.3 COMMISSIONING AND TESTING

When all connections have been made, the appliance and the overall installation must be checked following the directions given in this manual.

Check the following points:

Protective film has been removed from the external surfaces.

The lower front panel removed for the electrical connection has been replaced.

Connection has been made in accordance with the requirements and directions indicated in this manual.

All safety requirements in current standards, statutory regulations and directives have been met.

Water connections are leak-free.

Electrical connection has been completed according to standards.

In addition, check that when unit has been installed, the mains cable is not subject to stretching or that it is not in contact with any hot surface.

Proceed to light the appliance as directed in the instructions for use.

While appliance is in use, voltage should not differ from the nominal voltage more than +/- 10%.

The test report must be completed in full and submitted to customer who should then sign in acceptance.

With effect from this moment, the appliance is covered by the manufacturer's warranty.

2.4 MAINTENANCE OF THE APPLIANCE

Warning! : All maintenance operations shall only be performed by a qualified service engineer!

To ensure correct and safe operation, the unit must be inspected and serviced at least once annually. Maintenance should also include checking the condition of pipes, feed pipes, electrical components etc.

It is advisable to replace worn components during maintenance to avoid the need for further calls or unexpected failures.

It is also advisable to arrange a maintenance contract with a certified service agent.

2.4.1 POSSIBLE FAILURES AND THEIR ELIMINATION

Warning! : Only qualified service engineers should perform the operations described below!

Warning! : Before resetting safety thermostat, it is necessary to eliminate the cause of activation!

Problem and Possible Cause	Access to Components and Operation
The pan contents do not heat up: <ul style="list-style-type: none">– Safety thermostat has been activated;– Heating elements have failed;– Selector/switch failure.	Safety thermostat The safety thermostat can be accessed after lower front panel has been removed. Heating elements The heating elements can be accessed after lower front panel has been removed. Selector Switch - Operating thermostat To gain access, remove upper front panel.

Section 3: Use and cleaning

3.1 WARNINGS AND HINTS FOR USER

This manual contains all the instructions required for a proper and safe use of our appliances. Keep the manual in a safe place for future consultation!

This appliance is for catering use and must be used only by trained kitchen staff.

The appliance must always be kept under control during use.

Warning! : The manufacturer shall not be held responsible for injuries or damage due to non-compliance with safety rules or improper operator use of the appliance.

Improper operating conditions may be caused by improper use. It is important to train personnel properly.

All installation and maintenance operations must be performed by registered engineers.

Respect the periods required for maintenance. With this in mind, customers are recommended to sign a service agreement.

In case of failures concerning the appliance, all supplies (*electrical and water*) must be cut off instantly.

In case of recurrent failures, contact a service engineer.

3.2 INSTRUCTIONS FOR USE

Before cooking with the appliance for the first time, wash the pan interior thoroughly.

Warning! : Fill pan up to a maximum of 40mm below overflow mark according to the maximum level indicator, including the food to be cooked.

Warning! : Before filling pan, always check that the drainage tap is closed.

3.2.1 FILLING THE JACKET

Warning! The water level in the jacket must be checked each time before lighting.

Warning! It is advisable to use softened water to fill the jacket!

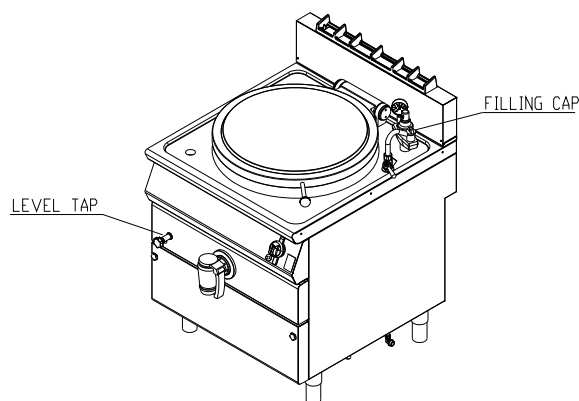

3.2.1. FILLING THE JACKET – MOD. 100-150LT

Open level tap at appliance front.

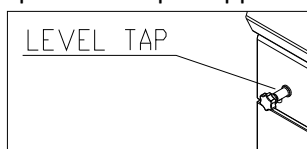

Undo filling cap on safety valve unit. This is located on the right of the appliance front (see diagram).

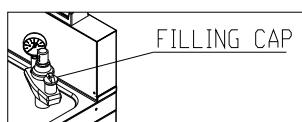

Fill with softened water (the capacity of the jacket is stated in the "Technical data" section).

When water starts to pour out of the level tap, close tap and replace safety cap.

3.2.2 DETAILS REGARDING OPERATION WITH PRESSURE KETTLE

Before turning unit on, close lid firmly and lock 4 screw clamps.

Check relief valve is in rest position.

Start cooking at full power. When steam starts to emit from valve, reduce heating power.

Steam emitting from valve must be constant and light.

Pressure inside pan may reach a maximum of 0.05 bar. Upon request, appliance can be supplied with a pressure gauge to indicate pressure inside pan.

Turn appliance off after cooking.

Before opening lid, release all pressure from pan by lifting relief valve lever (*see figure "Controls"*).

Check that valve lever is still "ON" and undo screw clamps.

3.2.3 SWITCHING ON, START COOKING AND SWITCHING OFF

Fill pan with hot or cold water, according to need, using tap that appliance is equipped with.

The unit has a three-position selector to start cooking functions (*see figure "Controls" on Page*).

Here is a list of the procedures for a safe and correct use of the appliance.

Energising the unit:

Turn ON appliance at main switch.

Start of cooking:

Turn control from position "0" to required heating position according to cooking requirements.

Green neon will light.

Cooking is generally started with control set to position "2"; when pan reaches cooking temperature, turn control to "1" to maintain this.

Set operating thermostat knob to desired temperature between 40 and 100°C.

Heating will start and orange neon will light automatically.

Orange neon will go out as soon as set temperature is reached.

To make water boil quickly, set control to a temperature of 100°C.

Heating elements operate continuously.

By turning selector from Position "2" to "1", it is possible to keep water boiling using less power.

3.3 CLEANING AND CARE OF THE APPLIANCE

Do not use aggressive substances or abrasive detergents when cleaning stainless steel components. Avoid using metal pads on steel parts as these may cause rust. For the same reason, avoid contact with materials containing iron.

Do not use sandpaper or abrasive paper for cleaning; in special cases use a powder pumice stone.

In case of particularly resistant dirt, it is advisable to use abrasive sponges (*e.g. Scotch-Brite*).

It is only advisable to clean the appliance only when it has cooled down.

3.3.1 DAILY CLEANING

Warning! : When cleaning appliance, never use a direct jet of water to prevent infiltration of the liquid and damage to components.

Clean pan with water and a detergent, rinse thoroughly and dry well with a soft cloth.

External surfaces should be washed down using a sponge and hot water with a suitable proprietary cleaner addend.

Always rinse thoroughly and dry with a soft cloth.

Notes regarding pressure kettles:

Do not use detergents containing high percentages of ammonia and sodium to clean lid gasket, as this may cause damage and affect the seal.

3.4 SPECIAL PROCEDURES IN CASE OF PROLONGED INACTIVITY

If appliance is to be idle for any length of time (*e.g. holidays or seasonal closing*) it must be cleaned thoroughly leaving no trace of food or dirt.

Leave lid open so that air can circulate inside pan.

For added care after cleaning, protect external surfaces by applying a proprietary metal polish.

Be absolutely sure to shut off all utilities (*electrical power and water*).

Air the room appropriately.

3.5 SPECIAL PROCEDURES IN CASE OF FAILURES

If appliance should not work properly during use, turn it off immediately and close or cut off all supplies (*electrical power and water*). Apply to a service centre for assistance.

The manufacturer shall not be held responsible nor has any warranty commitments for damage caused by non-compliance with prescriptions or by installation not in conformity with instructions. The same applies in case of improper use or different application by the operator.

3.6 HOW TO PROCEED, IF...

Warning! : Problems and failures may occur even when the appliance is used properly. Here is a list of the most probable situations and solutions that an operator should perform to avoid making an unnecessary service call.

If this does not solve the problem, turn appliance off immediately and unplug it. Isolate electrical and water supplies and call a service agent.

Pan contents do not heat up:

- **check** power ON/OFF switch is on;
- otherwise, **turn off appliance** and call a service agent. The safety thermostat may have been activated due to excess pan temperature. This may occur when unit is turned on and pan and/or jacket is/are empty.

Part 4: Figures and Details

4.1 WIRING DIAGRAM (400V)

C1	Electromagnetic switch MAX.	R1	Heating element
L1	Green operation light	SE	Selector
L2	Orange warning light	TL	Operating thermostat
MA	Line terminal board	TS	Safety thermostat
F2	Fender-fuse 3.15A	C2	Electromagnetic switch MIN.
		C3	Electromagnetic switch 30A security

* = SENSOR FOR SAFETY THERMOSTAT

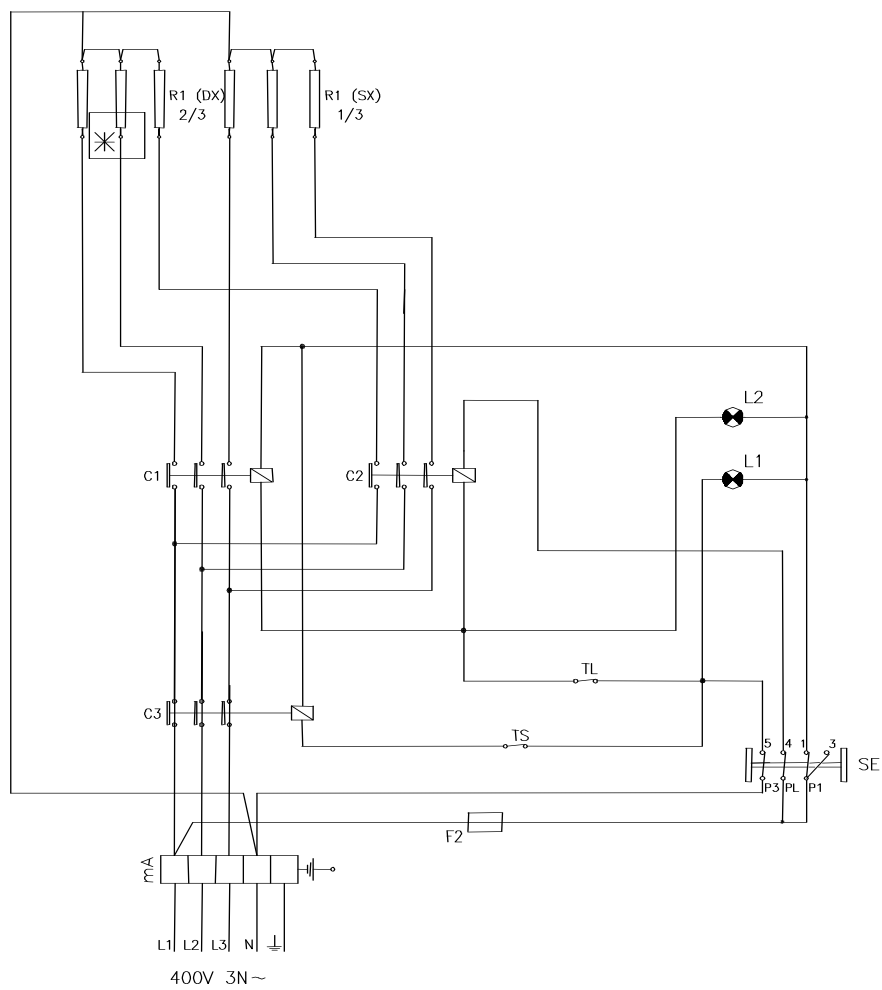

4.1 WIRING DIAGRAM (230V)

C1	Electromagnetic switch MAX.	R1	Heating element
L1	Green operation light	SE	Selector
L2	Orange warning light	TL	Operating thermostat
MA	Line terminal board	TS	Safety thermostat
F2	Fender-fuse 3.15A	C2	Electromagnetic switch MIN.
C1-S	Electromagnetic switch security	C2-S	Electromagnetic switch security

*** = SENSOR FOR SAFETY THERMOSTAT**

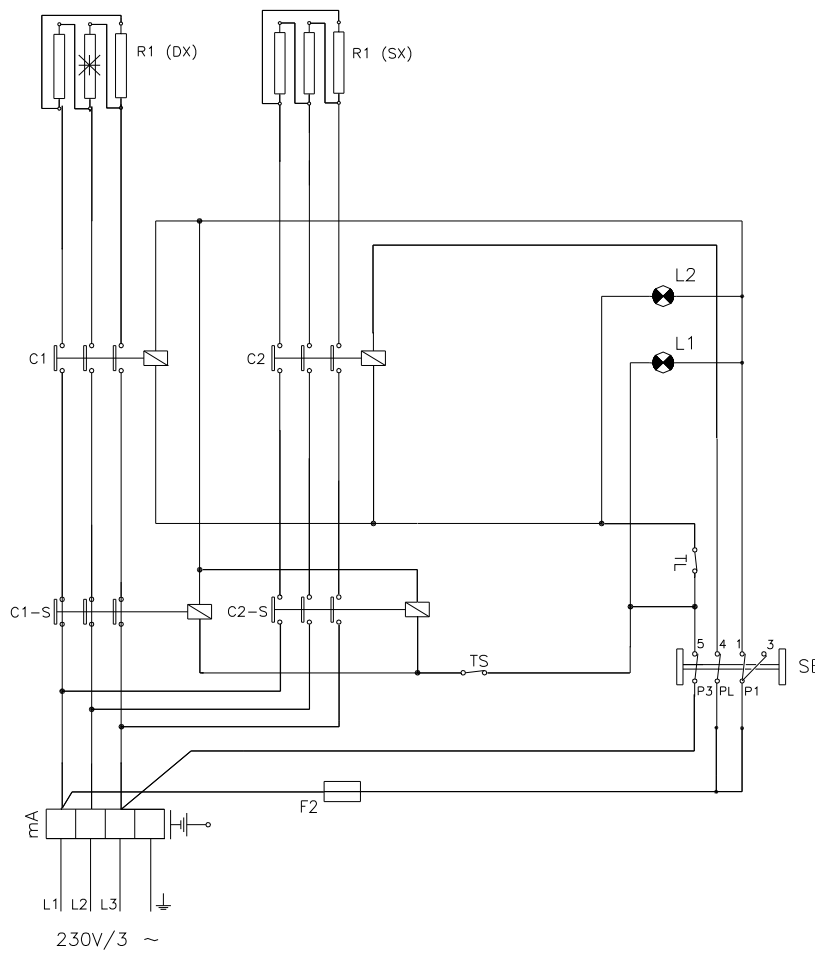

4.2 VIEW OF APPLIANCE

E - Electrical connection

S – Overflow

A - Water connection

1. Selector
2. Green warning light
3. Pressure gauge
4. Cooking pan drainage tap
5. Pan water feed tap
6. Jacket level tap
7. Orange warning light
8. Operating thermostat

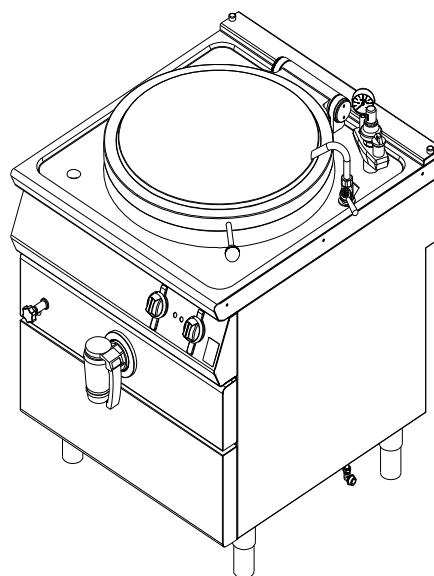
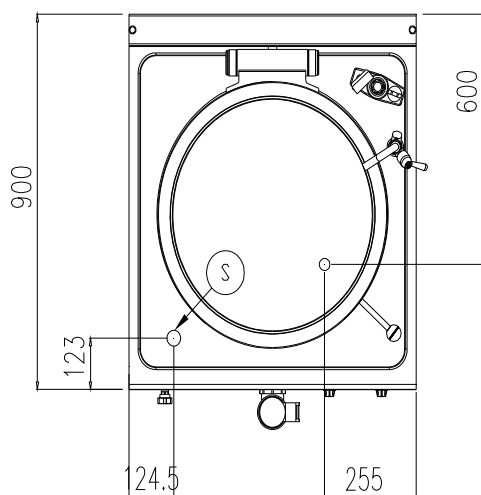
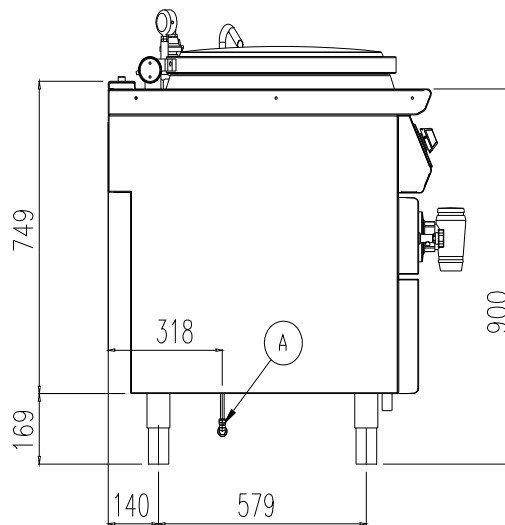
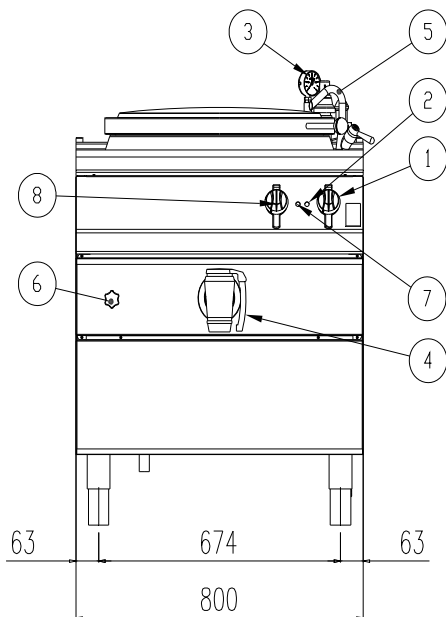

4.3 CONTROLS

Position 0 = Off

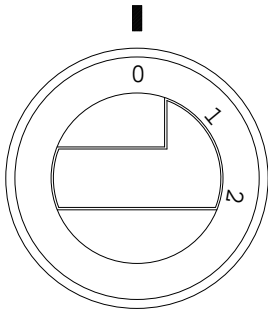

Position 1 = 50% power

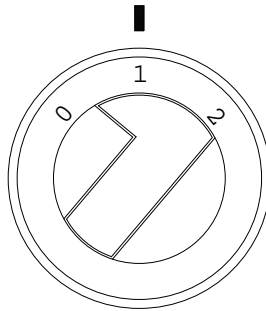

Position 2 = 100% power

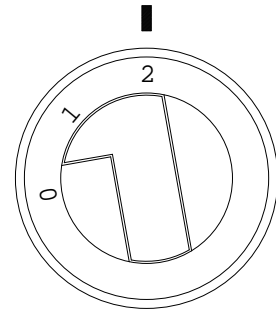

4.3.1 OPERATING THERMOSTAT

A - OFF

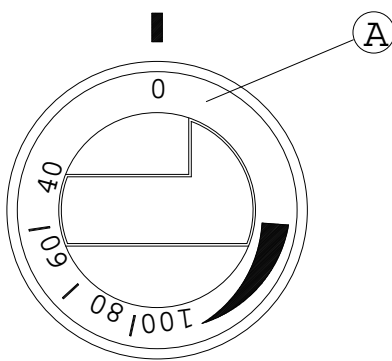

B - MAX

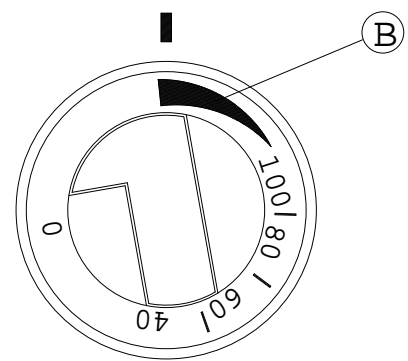

4.4 RELIEF VALVE (PRESSURE KETTLE ONLY)

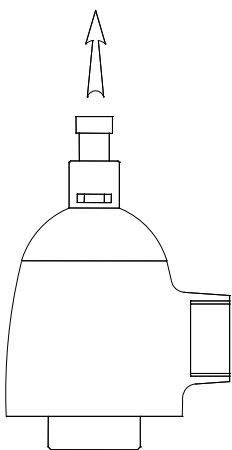

Valve in operating position

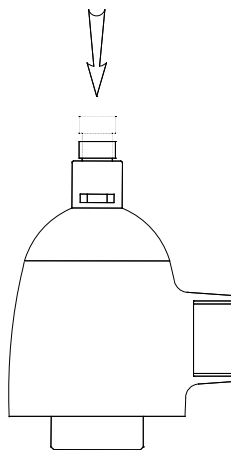

Valve in open position